

**OPERATION MANUAL
FOR
MICROCOMPUTER BASED
DIGITAL TEMPERATURE CONTROLLER
XMT*-808 series**

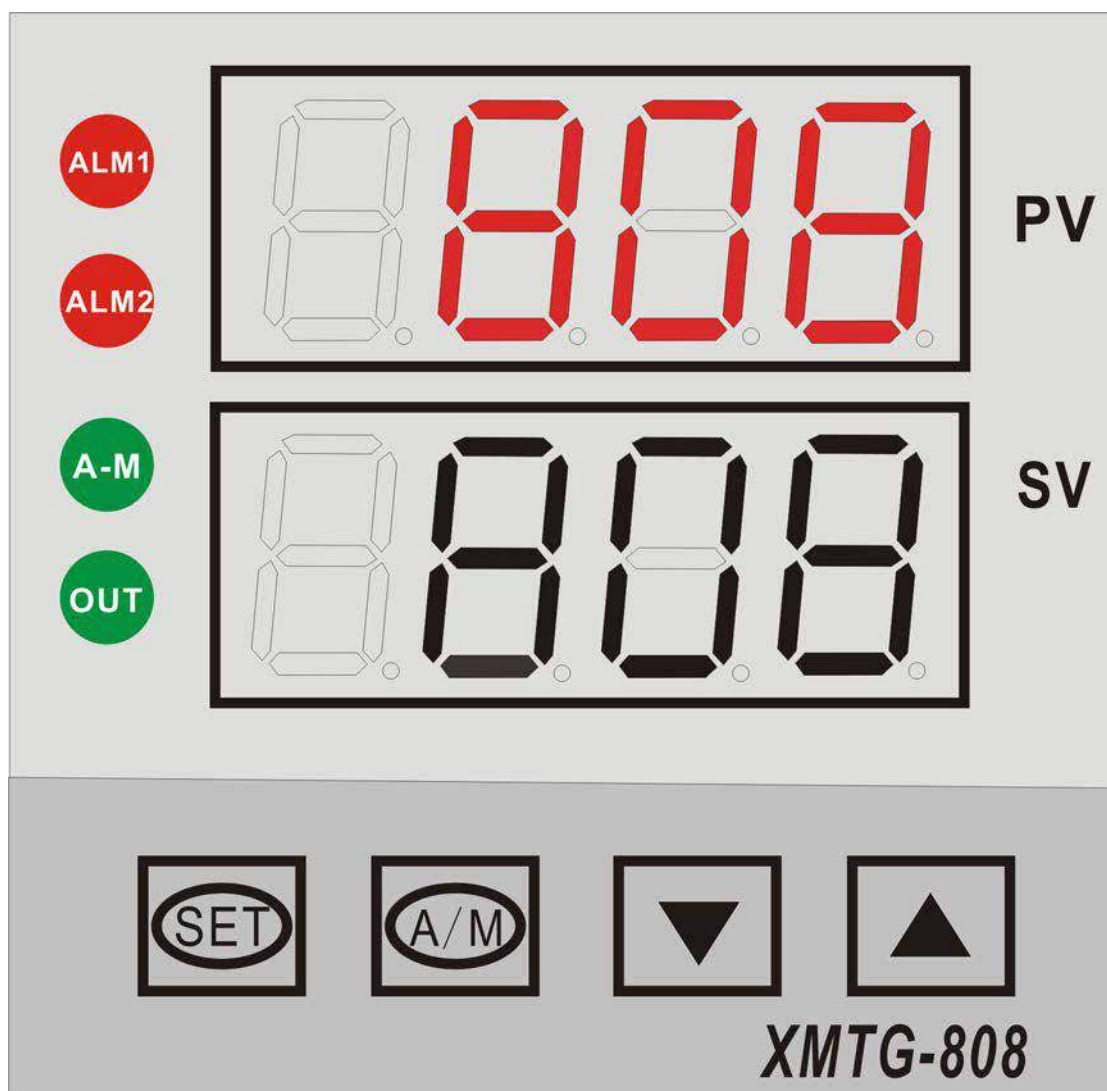

Catalog

Catalog	—1—
Safety notice mark	—3—
I Survey	—3—
II Technical standard	—4—
2.1 Input	—4—
2.2 Precision	—4—
2.3 Response time.....	—4—
2.4 Adjusting mode.....	—4—
2.5 Output specification	—4—
2.6 Communication	—4—
2.7 Alarm function	—4—
2.8 Insulate resistance voltage	—4—
2.9 Manual function	—4—
2.10 Power supply	—4—
2.11 Work environment	—5—
2.12 Product authentication	—5—
III Model selection	—5—
3.1 Model meaning	—5—
IV Installation and connection	—5—
4.1 XMT-808wiring diagram	—6—
4.2 XMTD-808 wiring diagram	—6—
4.3 XMTA/E/F-808 wiring diagram	—7—
4.4 XMTG-808 wiring diagram	—7—
4.5 SCR trigger wiring diagram	—8—
V Faceplate description	—8—
5.1 Faceplate chart	—8—
5.2 Faceplate explain	—8—
VI Basic setting and operation	—9—
6.1 Temperature fixed value setting.....	—9—
6.2 Parameter setting.....	—9—
6.3 Manual/Auto.....	—9—
6.4 Setting operation.....	—9—
6.5 Manual setting itself.....	—10—

VII	Function and setting	—10—
7.1	Operation flow chart	—10—
7.2	Parameter function description	—11—
VIII	Additional remarks of partial function	—16—
8.1	Linearity current output	—16—
8.2	Time proportion Control	—16—
8.3	Remote transmission pressure control	—17—
8.4	Thermocouple cold end compensating	—17—
IX	Common control method	—18—
9.1	ON/OFF adjustment and alarm	—18—
9.1.1	ON/OFF adjustment introduction	—18—
9.1.2	ON/OFF adjustment illustrate	—18—
9.2	Temperature transmission	—18—
9.2.1	Temperature transmission introduction	—18—
9.2.2	Temperature transmission illustrate	—18—
9.3	Communication function	—18—
9.3.1	Communication function introduction	—18—
9.3.2	Communication function connection	—19—
X	Fault analysis and clearance	—20—
	Attached1: Check list between parameter prompt letter and English letter	—20—

Safety Notice Mark

Before reading the instruction, it will turn up the below mark, shows “Danger”、
“Attention”。

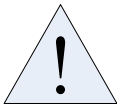
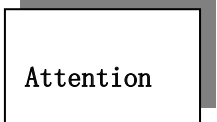
Danger		Procedures which may lead to dangerous conditions and cause death or serious injury, if not carried out properly.
Attention		Remind user of paying attention to special content or important content.

I 、 Survey

Thank you for the purchase of our XMT*-808 series microcomputer based digital temperature controller.

This manual contains instructions for the install, operations, parameter setting and abnormal diagnosis when operating the XMT*-808. please read and save this manual carefully before starting operation, so as to insure the steady.

XMT*-808 series intelligence temperature controller uses nowadays the most advanced monolithic microcomputer as mainframe, reduce peripheral assembly, and improve the reliability; It adopts the control method of vague theory combined with traditional PID control, and make the control process with the advantage of rapid response、 small overshoot、 high steady state precision. It is intelligence temperature controller with the function of high performance、 high reliability、 complete input, its function is suitable to all the occasion needed temperature measurement and control, also be compatible with other industrial parameter measurement and control.

It adopts modular structure, further improve overall performance; The meter is operated with 4-keys, dual row 4-LED display for displaying the measurement value and set value or measurement value and output value, with manual /automatic switch and setting itself function; with characteristic of small volume、 low power consumption、 convenient operation、 steady and reliable of running; They are now widely used for the automatic control system over the area of machinery, chemical, ceramics, light industry, metallurgy, petrification, heat treatment industry.

II、Technical standard

2.1、Input and range (one meter can be compatible):

- ① Thermal couple: K (-50~1300°C)、S (-50~+1700°C)、T (-200~+350°C)、E (0~800°C)、J (0~1000°C)、B (0~1800°C)、N (0~1300°C)、WRe(0~2300°C)
- ② Thermal resistance: CU50 (-50~150°C)、PT100 (-20~600°C);
- ③ Linearity voltage: 0~5V、1~5V、0~1V、0~100mV、0~20mV;
- ④ Linearity current (with diffluent resistance): 0~10mA、0~20mA、4~20mA
- ⑤ Linearity input: -1999~+9999 (user freely setting)

2.2、precision:

- ① Input by thermal resistance , linearity voltage and linearity current $0.5F \cdot S \pm 1$
- ② Thermocouple input adopt copper resistance or freezing compensate cold end $0.5 F \cdot S \pm 1$;
- ③ Although the meter can measure B、S、WRE during the temperature 0~600°C,its measurement could not reach 0.5 class;
- ④ differentiate rate: 1、0.1;

2.3、response time: $\leq 0.5s$ (filter parameter sets 0)

2.4、Adjusting mode:

- ① ON/OFF control method (Return difference can be adjusted);
- ② Common PID control (with the parameter of self-setting function)
- ③ Intelligence adjustment(including vague PID adjustment and advanced control algorithm with the parameter of self-setting function);

2.5、Output specification: it make out directly output parameter modularity or without modularity:

- ① The switch of relay contact point output (open+ closed): 250VAC/7A or 30VDC/10A;
- ② SSR voltage:12VDC/30mA(apply for driving SSR relay);
- ③ Contact point output with controllable silicon: can contact 5~500A two directions controllable silicon; 2 separate directions controllable silicon opposite direction parallel.
- ④ Liner electric current output: initial current and terminal current value can be defined when the output is 0~24mA (voltage range 11~23VDC);

2.6、Communication:

Support RS485communication mode, adopt AIBUS communication agreement, and baud rate support the below selection : 1200bps、2400bps、4800bps、9600bps

2.7、Alarm:

Support two passive contact output, relay contact 250VAC/7A; It has four methods including upper limit, lower limit, positive deviation ,negative deviation .It can output 2 ways at most;

2.8、Tolerance for pressure when it is segregated: Between electric power ,relay's contact and signal's end ,do 2000V pressure tolerance test 1s,there is no abnormal phenomenon;

2.9、Movement with hand: Automatic /Manual;

2.10、Power supply:

- ① 85V-242VAC, 50-60HZ; power consumption $\leq 4W$;

- ② 24VDC/AC power consumption \leq 4W;
- ③ 220VAC \pm 10% 50HZ; power consumption \leq 4W

2.11、working circumstance:

Environment temperature: 0~50°C, humidity \leq 85%, no corrode and strong electromagnetism disturb.

2.12、Product authentication:

XMT*-808 series temperature meter acquire CE authentication and ROHS Environmental Protection authentication.

III、Model selection

Model selection instruction

About XMT*-808 series intelligence temperature controller, we mark specific model on each piece. According to on site control request by itself, client should contrast the meaning of the product model code carefully before use and choose, to avoid wrong use or wrong model selection, or you can telephone to consult.

3.2 Product code

XMT 8 8
 (1) (2) (3) (4) (5)

(1) The surface dimension:

Blank:	160×80×120	Installation hole	152×76;
A:	96×96×110	Installation hole	92×92;
D:	72×72×110	Installation hole	68×68;
E:	48×96×110	Installation hole	44×92;
F:	96×48×110	Installation hole	92×44;
S:	80×160×120	Installation hole	76×156
G:	48×48×110	Installation hole	44×44

(2) Control Mode: ‘8’: four key set, two row LED display, fuzzy control.

(3) Additional alarm: ‘0’: no alarm ; ‘1’: one group alarm;
 ‘3’: two group alarms ‘5’: voice alarm

(4) Signal input type: ‘8’: freely exchange signal

(5) Suffix:

Main control output method:

- ‘Blank’: relay’s open and closed contact output;
- ‘A’: Single-phase over-zero spark pulse;
- ‘A3’: Three-phase over-zero spark pulse;
- ‘B’: Single-phase shift-phase spark pulse;
- ‘B3’: Three-phase shift-phase spark pulse;
- ‘C’: 0~10mA or 4~20mA constant electric current output
- ‘E’: Linearity voltage output;

‘G’： ON/OFF solid state relay (SSR) adjustment output;

Auxiliary ways:

‘K’： with RS485 or RS232 communication module interface;

‘Wt’： with micro-printer output signal;

‘V’： DC24V、 DC12V、 DC5V output; ‘P’： 30 segment program

IV、 Installation and connection

Connection explanation

XMT*808 series intelligence temperature controller, it provides the below wiring diagram for reference; Client can make the correct connection according to the meaning of the model code.; when find the wiring diagram is different from the meter model, or the order is the special specification, please be confirm to case connection, or you can telephone to consult.

4.1 XMT-808 wiring diagram

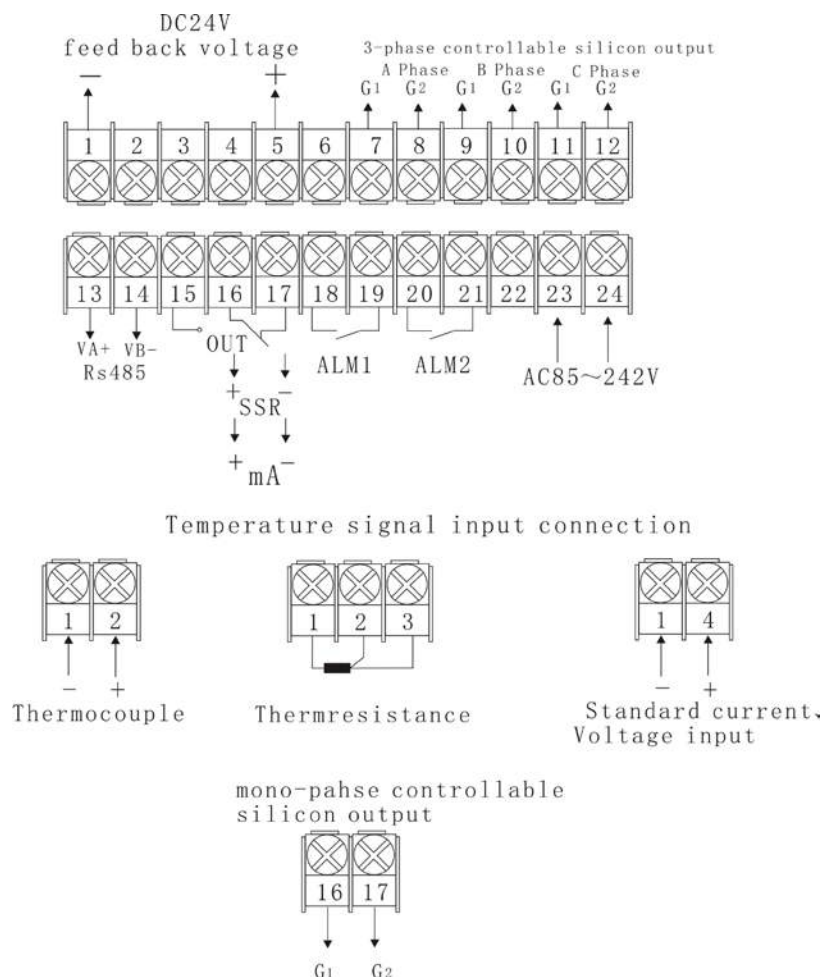

Figure 4—1

Note: linearity voltage range under 1V can input by terminal 1、 2, signal 0~5V and 1~5V can input by terminal 1、 4. 4~20mA linearity current input can achieve by changing 250Ω or 50Ω resistance to 1~5V or 0.2~1V voltage signal, and then input from 1、 2 terminal or 1、 4 terminal.

4.2 XMTD-808 connection

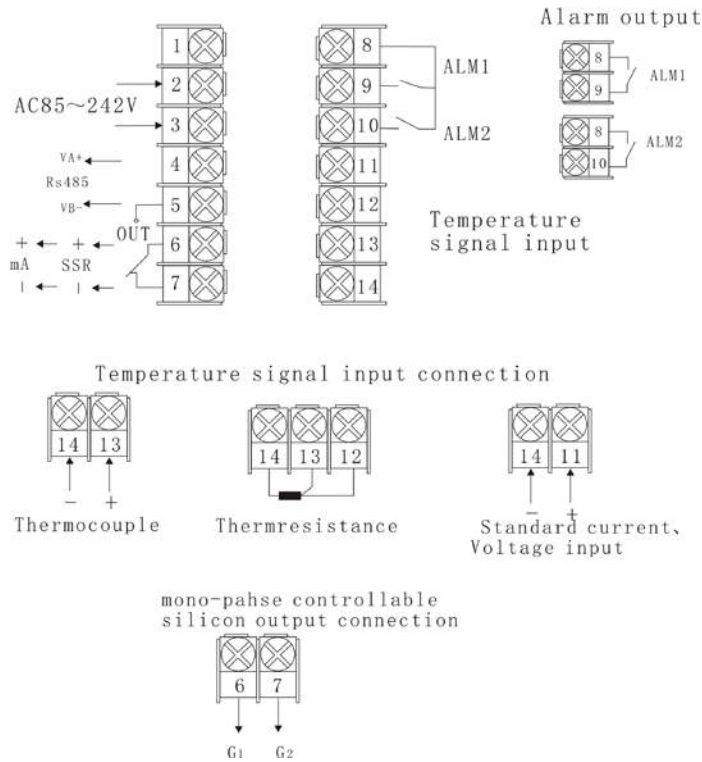

Figure 4-2

Note: linearity voltage range under 1V can input by terminal 13、14, signal 0~5V and 1~5V can input by terminal 11、14. 4~20mA linearity current input can achieve by changing 250Ω or 50Ω resistance to 1~5V or 0.2~1V voltage signal, and then input from 11、14 terminal or 13、14 terminal.

4.3 XMTA/E/F-808 wiring diagram

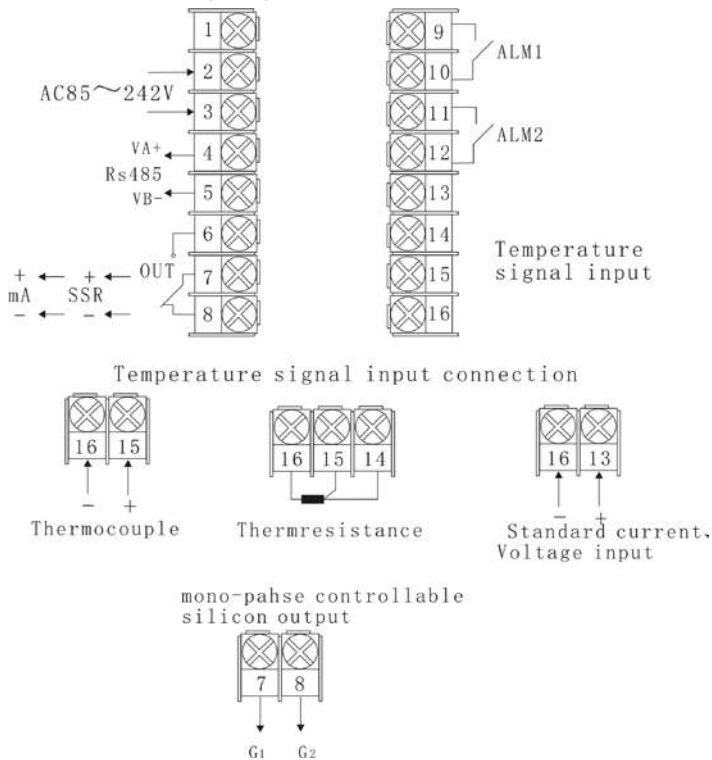

Figure 4-3

Note: linearity voltage range under 1V can input by terminal 15、16, signal 0~5V and 1~5V can input by terminal 13、16. 4~20mA linearity current input can achieve by changing 250Ω or 50Ω resistance to 1~5V or 0.2~1V voltage signal, and then input from 13、16 terminal or 15、16 terminal.

4.4 XMTG-808 connection

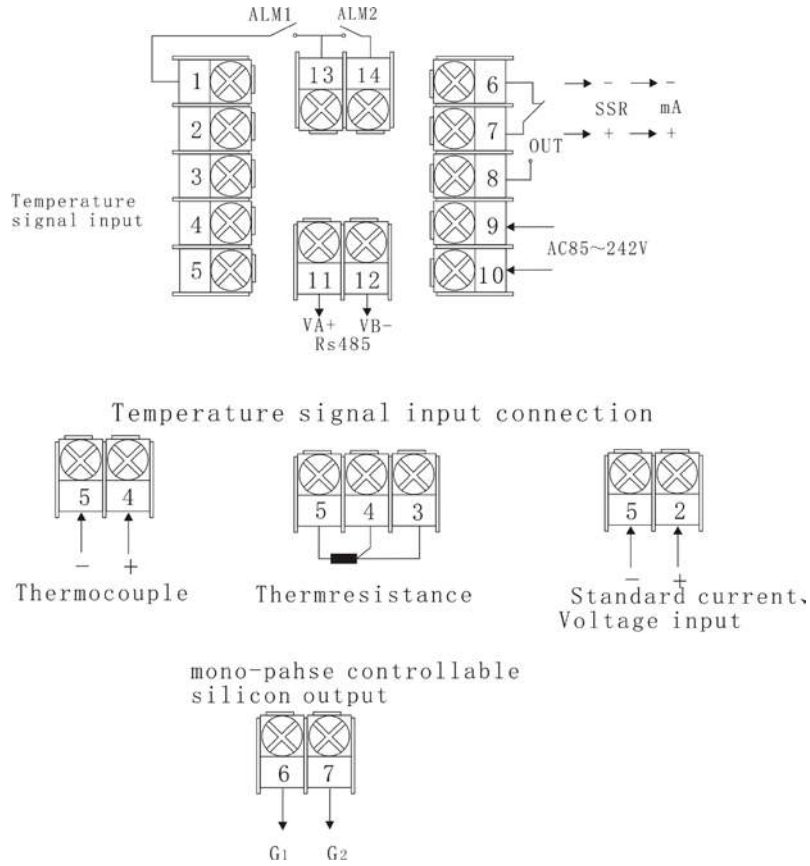
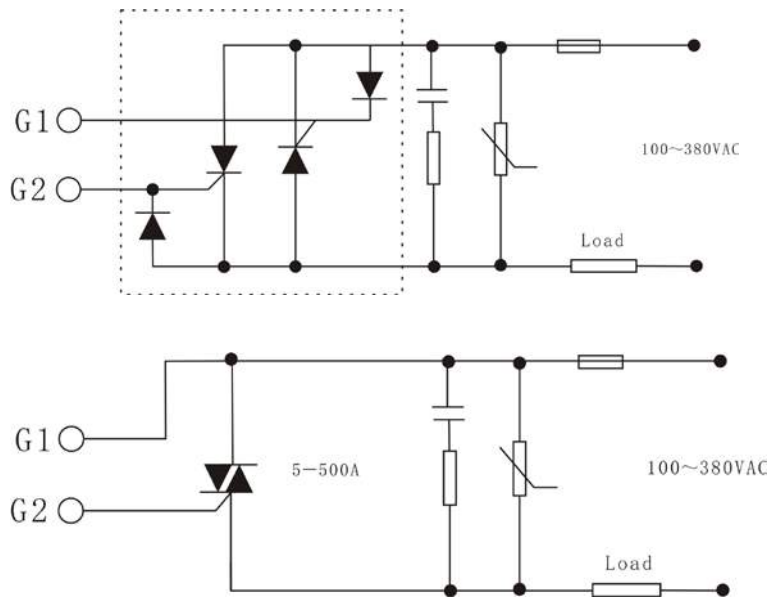

Figure4—4

Note: linearity voltage range under 1V can input by terminal 4、5, signal 0~5V and 1~5V can input by terminal 2、5. 4~20mA/4~20mA. linearity current input can achieve by changing 250Ω or 50Ω resistance to 1~5V or 0.2~1V voltage signal, and then input from 4、5 terminal or 2、5 terminal .

4.5 Controllable silicon contact connection



V、Panel Explanation

5.1 Panel chart

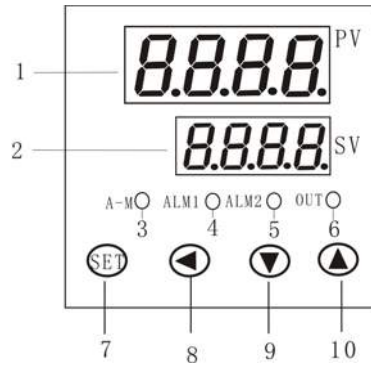

5.2 Panel explanation

- 1、PV----- Measured value indicator (red)
- 2、SV----- Set value indicator (green)
- 3、A-M----- manual indicator lamp or setting itself(green) If ramp/sock type, mean segment running indicator
- 4、ALM1----- AL1 indicator (red)
- 5、ALM2----- AL2 indicator (red)
- 6、OUT-----output indicator(green)
- 7、 SET-----function key
- 8、 ◀----- data automatic/manual shift function key
- 9、 ▼-----Data reduce key
- 10、 ▲-----Data addend key

When the power is on, the upper display window displays measured value (PV), the lower display window display set value (SV) .

There are 4 LED indicator on the faceplate, their meaning as below:

OUT indicator: when the linearity current output , output indicator reflect the current size by the change of output indicator's light and dark, when output with time scale method (relay、solid relay and controllable silicon contact output when it exceed zero. Scintillation time scale reflect output size.

ALM1 indicator: when ALM1 output is ON ,a red LED lights.

ALM2 indicator: when ALM2 output is ON ,a red LED lights.

A-M indicator: Manual indicator

★Attention:

Faceplate instruction just take XMTD-808 for instance , other model take XMTD-808 for reference.

VI、 Basic setting and operation

6.1、 Temperature fixed value setting.: Under normal condition, press ▲ or ▼ to enter into fixed value setting state, At that time, the lower nixie tube scintilla the decimal point, and then press ▼、 ▲、 ◀ (A/M) key to modify the setting data. Press SET to save and exit. If there is no button operation ,it will exit automatically the state after 10 s.

6.2. Setting parameter: press SET key for 3 second to enter setting parameter state. In this state press SET key ,the instrument will display each parameter in turn, for example, upper limit ALM1、parameter lock LOCK and so on, and for the instrument with good configuration and parameter lock, only display needed parameter (the parameter on site) .Use ▼、▲、◀ (A/M) key can modify the parameter data.First press◀ (A/M) key and simultaneity press SET key can exit the setting parameter state.If there is no button operation ,it will exit automatically the state after 10 s.

6.3. Manual/Automatic mode switch (A-M=0): press◀ (A/M) key can make the instrument switch between A/M. If the instrument works on Manual mode ,its output value can be increased or decreased by pressing ▲key or ▼key under display status, and the lower display the first word ‘M’. If the instrument works on AUTO mode, press SET key can look for the automatic output data(the lower display the first word“A”).Through parameter setting ‘A-M’ (refer to the back instruction) can make the instrument don’t allow to switch to manual mode by panel button operation in case that enter the manual mode blind.

6.4. Setting itself (At): Use the instrument at first time, start the function setting itself to assure P、I、d control parameter. First do this ,switch the instrument into normal display state ,press◀ (A/M) key for 3 second (AT=1), the lower display alternately “At”. when the instrument setting itself, the instrument use ON/OFF control, after 2-3 times ON/OFF,it will calculate automatically P、I、d control parameter. If stop setting itself in advance ,press◀ (A/M)key for 3s, and make “At” disappeared .For different system, the time setting itself needed is different. After finishing the setting itself successfully ,the instrument will set parameter At to 3, so it will not set itself through press◀ (A/M) key on the panel so as to avoid artificially by accident to restart the setting itself. The instrument can set parameter At to 2 when it restart after one time . (reference the back article “parameter function”description) .

Before doing setting itself,it should set the assigned data into the common data or the median, if the system is an electric cooker with good heat preservation property, the assigned data should be set the biggest data allowed before start. The setting of Parameter t (Control period) and Hy (return difference) will effect the process of setting itself .In a general way ,for these two parameter ,the setting data are smaller, the parameter accuracy will higher. But if Hy data is smaller,the instrument will be brought ON/OFF adjustment wrong action ,it will set wrong parameter .Command t=0-2, Hy=0.3。

★Attention:

Avoid no load setting when setting itself ,it should be ineffectual when it set with no load.

6.5. (Movement with hand)Setting itself: As it adopt “ON/OFF ” adjustment, its output can be positioned in the place defined by parameter outL and outH. In the occasion where didn’t allow big extent change, such as the occasion some actuator adopt controlling valve, the common setting itself is not suitable ,it only need to set with hand. Firstly adjust with hand, after the adjustment is stable, then use it automatically, so the output value will be limited in the current hand movement value range of +10% and -10% range ,not the range defined by outL and outH, consequently it avoid not allowing valve’s big extent change. Besides, Movement with hand will get more

accurate result when the controlled physical quantity 'response fast.

VII、 function and setting

7. 1 Operation flow chart

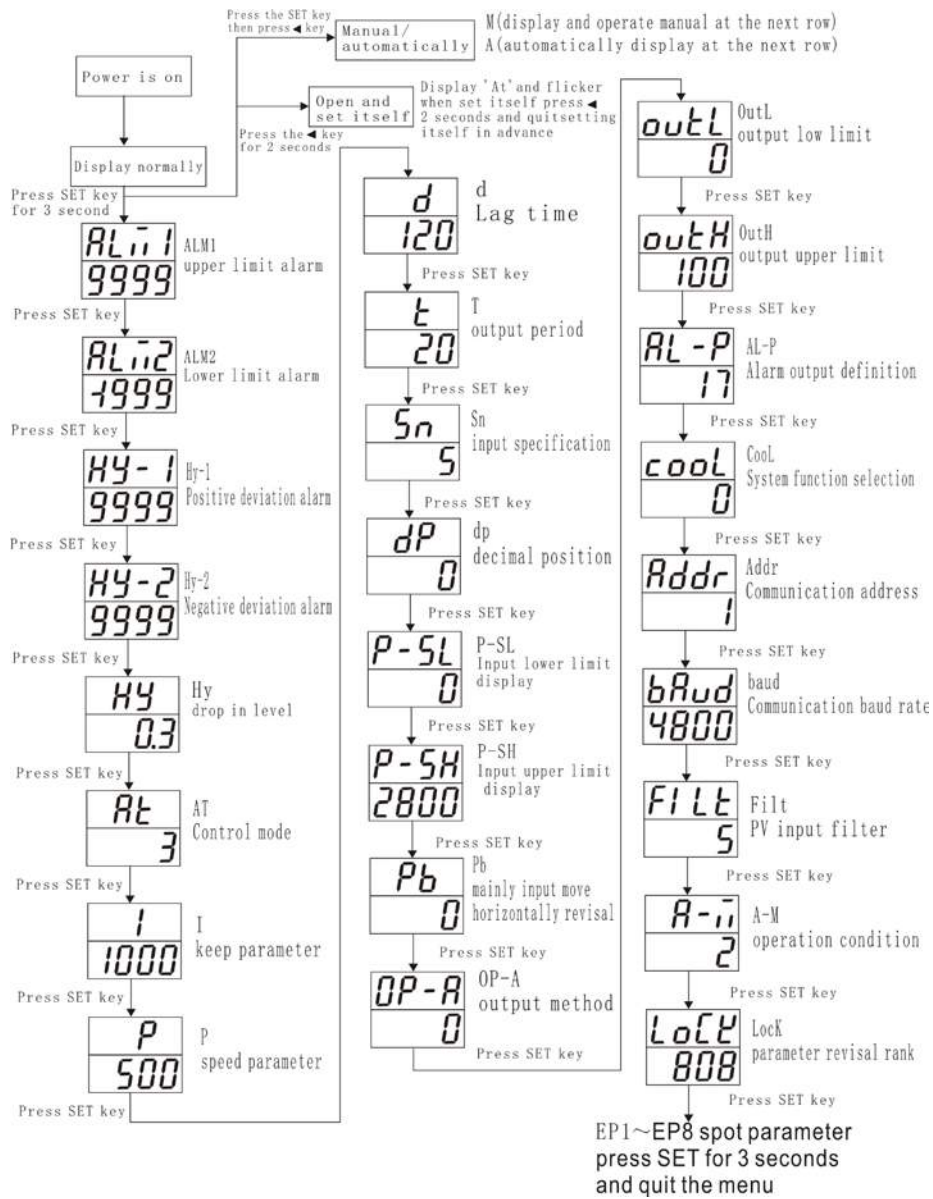

7. 2、 Parameter function description (Meter's input ,output, alarm and control method can be defined by parameter.)

Code	Meaning	Description	Setting range	Ex-Factory
ALM1	High limit alarm	When the measured value more than ALM1+Hy, the meter have upper limit alarm. When the measured value less than ALM1-Hy, the meter will free from the upper limit alarm. Set the ALM1 =9999 can avoid come into being alarm function.	-1999~+9999°C or 1 unit	9999°C
ALM2	Low limit alarm	When the measured value less than ALM2-Hy, the meter have lower limit alarm. When the measured value more than ALM2+Hy, the meter will free from the lower limit alarm. Set the ALM2=-1999 can avoid come into being	The same as above	1999°C

		alarm function		
Hy-1	Positive deviation alarm	When the deviation (PV-SV) > Hy-1+Hy, the meter have positive deviation alarm. When the deviation less than Hy-1-Hy, the meter will free from the positive deviation alarm. If set the Hy-1=9999 (temperature is 999.9°C), the alarm will be cancelled. When use ON/OFF adjustment, Hy-1 and Hy-2 are the second upper limit and lower limit absolute value alarm.。	0~ 999.9°C or 0 ~ 9999°C 1 unit	9999°C
Hy-2	Negative deviation alarm	When the negative deviation (SV-PV) >Hy-2+Hy, the meter have negative deviation alarm. When the negative deviation (SV-PV) <Hy-2-Hy, the meter have no negative deviation alarm. Set the Hy-2=9999(temperature is 999.9°C), the alarm will be cancelled	The same as above	9999°C
Hy	Dead band	Hy is set to permits protection of position control output from high switching frequencies caused by process input fluctuation. If the meter use ON/OFF adjustment or parameter setting itself , provided appointed value SV is 700°C, Hy is 0.5°C, by reaction adjustment (heating control) (1) Output is switch on , when the measure temperature value is more than 700.5°C, the (SV+Hy) will close. (2) Output is switch off, when the measure temperature less than 699.5°C (SV-Hy), switch on again and heating.	0-200.0 °C or 0-2000°C	0.5
At	PID Control method	At=0, ON/OFF control, suitable for the application which don't need high precision. At=1, artificial intelligence control / PID control, allow to set the auto tuning function from front panel. At=2, startup auto tuning function, after auto tuning finish, it will set 3. At=3, artificial intelligence control. After auto tuning finish, the meter automatism enter into this set, this setting don't allow to set from front panel.	0-3	1
I	Hold parameter	I, P, D, t these parameter are for artificial intelligence control algorithm, but no for ON/OFF control mode (At=0). I is defined as measurement variation after output is changed. Generally I parameter of the same system will changes with measurement value, and so I parameter should be configured with process value around operation point. For example: take temperature control of electric furnace, operating point is 700°C, to find out optimum I parameter, assuming that when out remains 50%, the temperature of electric furnace will finally be stabilized around 700°C, and when output changes to 55%, the temperature will final be at around 750 °C . The I (optimum parameter)=750-700=50.0 (°C) I parameter mainly determines the degree of integral function, similar as integral time of PID control. When the I smaller, the calculus function strong. When the I larger, the calculus function weaken (calculus time add). When I=0, the system will cancel the calculus function and	0-999.9 or 0-9999	500

		artificial intelligence adjustment function, the instrument will turn to an PD adjustment.		
P	Rating parameter	<p>P is in reverse proportion to measurement variations caused by output changes by 100% in one sec..</p> <p>When $A_t=1$ or 3, then $P=1000 \div$ measurement elevatory value per sec. , the unit is 0.1°C or 1 defined unit.</p> <p>Example: the instrument use 100% power to heat and there is no heat loss, electric cooker 1°C each sec., then $P=1000 \div 10=100$. P like PID instrument's proportion area, but diversification is reverse. $P \uparrow$, the proportion and differential function \uparrow , if $P \downarrow$, the proportion and differential function \downarrow . P parameter and calculus function have no relation. Set $P=0$ corresponds to $P=0.5$</p>	1-9999	100
d	Lag time	<p>Parameter "d" is applied as one of the important parameters of XMT808 artificial intelligence control algorithm. "d" is defined as follows: time needed for a electric furnace from the beginning of elevating temperature to get to 63.5% against the final speed of temperature elevating, provided there is no heat loss. The unit of parameter "d" is second.</p> <p>For industrial control, hysteresis effect of the controlled process is an important factor impairing control effect. The longer is system lag time, the more difficult to get ideal control effect. Lag time parameter "d" is a new introduce important parameter for XMT808 artificial intelligence algorithm. XMT808 series instrument can use parameter "d" to do fuzzy calculation, and therefore overshoot and hunting do not easily occurs and the control have the best responsibility at the time.</p> <p>Parameter "d" gives effect on proportion, integral and differential function. Decreasing parameter "d" will strengthen proportional and integral function and weaken differential function, with the extent of strengthening greater than that of weakening. And therefore as a whole decreasing "d" will strengthen feedback function. If $d \leq T$, derivative function of system will be eliminated.</p>	0-2000s	100
t	Output period	<p>Parameter can be set between 0.5 to 125s (0 means 0.5s). It represent the instrument of the calculate speed. When $t \uparrow$, the proportion function \uparrow , differential function \downarrow . When $t \downarrow$, the proportion function \downarrow , differential function \uparrow . When $t \geq 5s$, differential function is absolutely eliminated, then the system is a proportional or proportional-calculus adjustment. If the t less than 1/5 of its lag time, the change is very small influence to control. If $d=100$, the t set 0.5 or 10s the control effect basic is same.</p> <p>(1) it is insignificant when ON/OFF control ;</p> <p>(2)Relay output: 't' usually be set 10s upwards, other output method be set 1~2s; output is relay output, the shorter the time, the better the control effect ,but it will</p>	0-120s	20

		affect the relay's life.					
Sn	specification Input	Sn Input specification:		0-37	0		
		Sn	Input spec.			Sn	Input spec.
		0	K			1	S
		2	WRe			3	T
		4	E			5	J
		6	B			7	N
		8-9	special thermocouple			10	ient appointed to increase input specification
		11-19	special thermocouple			20	CU50
		21	PT100			22-25	Special thermal resistance
		26	0-80 Ω resistance input			27	0-400 Ω resistance input
		28	0-20mV voltage input			29	0-100mV voltage input
		30	0-60mV voltage input			31	0-1V (0-500mV)
		32	0.2-1V voltage input			33	1-5V voltage input or 4-20mA current input
		34	0-5V voltage input			35	-20-+20mV (0-10V)
		36	-100-+100mV or 2-20V voltage input)			37	-5V-+5V (0-50V)
dP	Decimal point position	<p>When it is linearity input: parameter dP is used to define decimal point place according to users' habit dP=0, display pattern is 0000, decimal point not displayed dP=1, display pattern is 000.0, decimal point is at ten's place dP=2, display pattern is 00.00, decimal point is at hundred's place dP=3, display pattern is 0.000, decimal point is at thousand's place</p> <p>In case of thermocouple or RTD input: dP is used to define temperature display resolution</p>		0-3	0		
		<p>dP=0, temperature display resolution is 1°C dP=1, temperature display resolution is 0.1°C Adjustment of this parameter only affects the display, and gives no effect on control precision or measurement precision</p>					

P-SL	Input lower limit	<p>(1) When the linearity input define single lower limit value, external appointed, output display. For example: a pressure transmitter is used to convert pressure signal (temperature, flow and humidity signals also possible) to standard 1-5V input (4-20mA can external contact 250Ω resistance to change). 1V signal pressure is 0, 5V signal pressure is 1mPa, if want the instrument display is 0.001mPa. the parameter can be set as the following: Sn=33 (select 1-5V linearity voltage input) dP=3 (set decimal point, display 0.000) P-SL=0.000 (define the pressure display value when the input lower limit 1V) P-SH=1.000(define the pressure display value when the input upper limit 5V)</p> <p>(2) When the thermal resistance, thermocouple input defining lower limit appointed value.</p>	-1999~ +9999℃	0
P-SH	Input upper limit	When the linearity input defining single upper limit value, use with P-SL .	The same as above	2000
Pb	Input shift	Parameter Pb is used to make input shift to compensate the error produced by sensor or input signal itself. For thermocouple input, parameter Pb is used to correct reference junction compensation error.	-199.9 ~ +199.9 ℃	0
oP-A	Output mode	Op-A denote output signal mode, and must conform to the module type installed as main output. Op-A=0, the mode of main output is time-proportional output (for artificial intelligence control) or ON/OFF mode (for ON/OFF control). If output modules such as SSR voltage output or relay contact discrete output, it should set Op-A=0. Op-A=1, any specification linear current continuum output, Op-A=2, time proportional output	0-2	0
outL	Output lower limit	Restrain minimum value of adjust output	0-110%	0
outH	Output upper limit	Restrain maximum value of adjust output.	0-110%	100
AL-P	Alarm Output definition	<p>AL-P used to define ALM1, ALM2, Hy-1 and Hy-2 alarm output locality. Its function is determined by the following formula: AL-P= A x 1 + B x 2 + C x 4 + D x 8 + E x 16 If A=0, then upper limit alarm by the relay2 output If A=1, then upper limit alarm by the relay1 output If B=0, then lower limit alarm by the relay2 output If B=1, then lower limit alarm by the relay 1 output If C=0, then positive deviation alarm by the relay 2 output If C=1, then positive deviation alarm by the relay1 output</p>	0-31	17

		<p>If D=0, then negative deviation alarm by the relay 2 output If D=1, then negative deviation alarm by the relay 1 output If E=0, then alarm types, such as “ALM1” and “ALM2” will be displayed alternately in the lower display window when alarm occurs. For example: If it need that the upper limit alarm by the alarm1 relay output, lower limit alarm、 positive deviation alarm and negative deviation alarm by alarm2output, when alarm occurs no alarm type display in the lower display window. Then we reach a conclusion: A=1、 B=0、 C=0、 D=0、 E=1, and parameter “AL-P” should be configured to: AL-P= 1x1+0x2+0x4+0x8+1x16=17</p>		
Cool	System function	<p>COOL is used to select some system function: $Cool=A \times 1+B \times 2$ A=0, reaction control mode, if the input increase, the output will diminishment like heating control; A=1, direct action control mode, if input increase, output will increase like cooling control. B=0, without the function of alarm while at the power on or SV change B=1, have the alarm function while the power on and when the SV change have no alarm function.</p>	0-7	2
Addr	Communication address	When the instrument have RS485 , Addr can be configured the ranged of 0 to256 In the same communication line’s instruments, every one need have a different address.	0-256	0
bAud	Communication Baud rete	When the instrument have communication interface, parameter bAud is communication baud rate, the range is 300-19200bit/s (19. 2K) .	—	9600
FILt	PV input filter	When the FILt value set large, the measurement value is stabilized but the response time is longer. .	0-20	0
A-M	Operation condition	<p>A-M is define manual / automatic control state A-M=0, manual control state A-M=1, automatic control state A-M=2, automatic control state, in this state manual operation is prohibited. When the manual function is not required, it can avoid entering manual state due to operator’s false operating. If use the RS485 to control the instrument, the transfer of automatic/manual status can be carry out by adjusting parameter A-M from computer. When the meter is ramp/sock type, the A-M parameter will change to power failure handling function, please refer to 《XMT*-808P 30 Segment Program Type Insruction Manual》 .</p>	0-2	1

Lock	lock	<p>Lock=0, can set locale parameter and SV. Lock=1, can display and view the locale parameter, but don't to modification. The SV can set. Lock=2, can display and view the locale parameter, but the locale parameter and SV all cannot modification. Lock=808, all the parameter and SV can set.</p> <p>When the Lock is set other values except 808, then only locale parameter the range of 0 to 8 r and parameter Lock itself can be display and set.</p>	0-9999	808
EP1-EP8	Field parameter definition	<p>When configuration of the instrument is completed, most parameters will not need to be locale operators. Furthermore, locale operators may not understand many parameters, and may probably set parameters incorrectly by mistake and make the instrument unable to work. EP1-EP8 defines 1-8 locale parameters for operators' user in parameter table. Their parameter values are parameters except parameter EP itself like ALM1、ALM2, etc. When LOCK=0,1,2 and so on, only be defined parameter can display, other parameters can not be displayed and modified. This function can speed up the parameter modification and prevent important parameters (like input, output parameters) from modifying falsely. Parameter EP1-EP8 can define 8 locale parameters at most, if the number of locale parameters is less than 8 (sometimes even none), it is necessary to define useful parameters from EP1-EP8 in order, the first parameter which are not used is defined as none. For example, two parameters of ALM1 and ALM2 are need to be modified by locale operators, the parameter EP can be set as follows: Loc=0、EP1=ALM1、EP2=ALM2、EP3=nonE Sometimes locale parameters are not needed after we finish adjusting the instrument, we can set EP1 parameter an nonE</p>	—	none

VIII、 Additional remarks of partial function

8.1 linear current output

Any specification linear current continuum output. (OP-A=1): output upper limit and output lower limit define the instrument's current output specification, and its range can set at random between 0-22mA,for example output 0-10mA,so the setting is outL=0,outH=100(unit is 0.1mA),4-20mA can be set outL=40,outH=200,and it can also define nonstandard output,for example output 2-8mA, set outL=20,outH=80 and so on .During setting,output can be valid when outL is less than outH.

8.2 Time proportion control

Time proportion output (OP-A=2; OP-A=0 relay output or SSR voltage output: In case of time proportional output mode,the output value can change by adjusting,during a fixed base period,the ratio of on-off time(or the ratio of the time during which SSR high voltage output or low voltage

output is activated).

Time proportional output can be regarded as a square wave, the base period of which equals to control period "T", and the output value of which is directly proportional to the on-off ratio of the square wave. The on-off ratio may be configured to be in the range of 0% to 100%. For special applications, the range of time proportional output can be clamped by tuning parameters "OutL" and "OutH". For example, if the output needs to be clamped to between 20-60%, then OutL=20, OutH=60 may just be set. Normally in case of time proportional output, if OutL=0, OutH=100 is set, then there will be no output limit.

★Attention:
when OP-A=2, there is no alarm output

8.3 Long distance transfer pressure control

YTZ-150 resistance long distance transfer pressure gauge mating setting method: instrument setting parameter Sn=27

dP decimal point position, P-SL Input lower limit, P-Sh input upper limit Pb input shift

$$\text{Account expressions: } P-SL = -\frac{\text{Display range}}{\text{Resistance range}} \times \text{origination resistance} + \text{origination range}$$

$$P-SH = \frac{\text{Display range}}{\text{Resistance range}} \times (400 - \text{full range}) + \text{full range}$$

(Note: Display range = display upper limit data – display lower limit data; resistance range = long distance transfer resistance pressure gauge range's correspondent resistance data; starting resistance = long distance transfer resistance pressure gauge's correspondent resistance data; full range resistance = long distance transfer resistance pressure gauge full range's correspondent resistance data; starting range = display lower limit data; full range = display upper limit data;)

8.4 thermocouple cold junction compensate

Using connection method to choose thermocouple cold junction automatically compensate mode

When adopt thermocouple as signal, it should do temperature compensate to thermocouple according to the testing principle, XMT-808 series instrument can measure the temperature near the instrument's back connection terminal and do automatically compensate to thermocouple, as the deviation of testing component, the instrument itself turn hot or the other heat source near the instrument (the temperature of connection terminal will also rise), it will cause the deviation of automatic compensate mode turn bigger. so it need to adopt copper resistance compensate the high precision request. 808 series instrument can use the different to choose several compensate mode, so as to provide flawless thermocouple compensate scheme.

(1) Inner automatic compensate: when the instruments leave factory ,they are all adopt this mode to satisfy the most industrial application. but as for the flamestat installed in the inner, and it easily effected when the instrument got hot or effected by compensating lead wire and ambience, and deviation temperature can reach 2-4°C。

(2) Circumscribe CU50 copper resistance sensor compensating: place a connection box, put CU50 copper resistance (it need to buy) and the terminal cold junction together far away from the several heat object,so the testing deviation will be less than 0.5°C.As CU50 copper resistance itself deviation will cause room temperature with a little deviation,it can use SC parameter to modify. Change the outer connect copper resistance to precision fixed resistance can achieve constant temperature bath function.

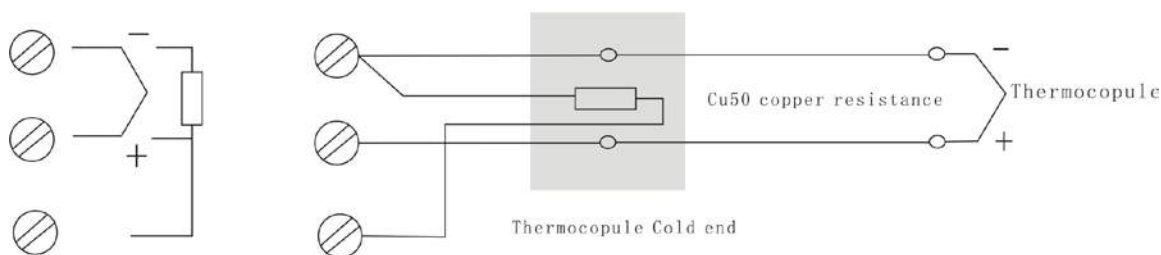

Figure 8-1

IX、 Instrument common working method

9.1 ON/OFF adjustment/Alarm

9.1.1 ON/OFF adjustment Introduction

ON/OFF adjustment (ON/OFF) is an easy adjustment method, it usually used for temperature control or alarm to that with low control precision occasion. When using ON/OFF adjustment, it use the inner relay to control the middle of outer relay and then control AC contactor to control heating wire 's on/off to achieve the temperature control.

Parameter Hy can determine dead band of ON/OFF adjustment. AT=0,OP-A=0,parameter Cool's A can used to decide adjustment direction of positive interaction or counteractive, Cool.A=0 时,OUT is heat control ,Cool.A=1,OUTis refrigeration control, the instrument below display window SV is setting point.

9.1.2 ON/OFF adjustment illustrate:

For example: heating installation, temperature control requirement as follows: temperature rise to 100°C,stop heating, lower to 96°C start heating, temperature exceed 110°C will alarm, lower than 50°C will alarm.

According to the above request, choose XMT*838 series, set the below parameter: set temperature fixed value (SV=98) ,set setting itself parameter (At=0), set main control return difference (Hy =2) ,set upper limit alarm (ALM1=110) ,set lower limit alarm (ALM2=50)。

9.1.3 Alarm function

Besides ON/OFF adjustment ,there is also 2-ON/OFF adjustment,3- ON/OFF adjustment,

4- ON/OFF adjustment or add alarm output, it should use alarm function ,so it make up of

upper-lower limit alarm、 upper-upper limit alarm and lower-lower limit alarm instrument. XMT808 series have ALM1、 ALM2、 Hy-1、 Hy-2 4 alarm setting point ,during ALM1、 ALM2、 Hy-1、 Hy-2 these alarm parameter which aren't used should be set limit data(the data have be set before leaving factory), so as to avoid unnecessary action.

9.2 Temperature transmitter

9.2.1 Introduction

XMT808 series instrument can set measurement value to linearity current output of any range ,and used as a instrument with display and temperature transmit function. Transmit precision durng 0-20mA,the deviation is less than 0.1mA,parameter setting as follows:

- a、 AT=0:current output is transmit current;
- b、 OP-A=1: linearity current output
- c、 outL、 outH: transmit current output range
- d、 P-SL 、 P-SH: transmit temperature range

9.2.2 Give examples

For example: the temperature range is 0-400°C, output is 4-20mA.So the parameter setting should be: AT=0、 OP-A=1 P-SL=0、 P-SH=400、 outL=40、 outH=200.so the transmitter can be defined ,when the temperature is less than 0°C, output is 4mA, when the temperature is bigger than or be equal to 400°C, output is 20mA, between 0-400°C, output between 4-20 mA change continuously.

9.3 Communication function

9.3.1 communication function introduction

808 series meter can configure photoelectric isolated RS485 communication interface, adopt AIBUS communication agreement, through computer all the meter 's operation and function can be completed. Except consumer s' all kinds of application software developed by themselves, the factory also provide AIDCS application software, which runs under WINDOWS 95/98/NT/XP operating system, can centralized monitoring and manage for 1~256pcs 808 series model meter, and also can automatically record measurement data and print. The meter adopt RS485 communication interface, the computer needs to add one RS323C/RS485 transducer, this way can connect 64pcs meter at most, as follows figure (10-1); add RS485 repeater can connect 100pcs meters, one computer with two communication interface can connect 100pcs meter. To pay attention that each meter should be set different address, when meter's quantity is big ,use 2pcs or more piece computer, each computer makes up of local area network. According to communication agreement ,customers can develop configuration software themselves, or use Kunlun configuration software. All of our meter with communication function add into Kunlun configuration software, Customers can buy configuration software directly from company.

Communication interface is 8 digit data bit, 1digit or 2 digit stop bit, without parity bit; The data adopt 16 digit summation check, its correction capability is countless thousands fold higher than parity check, to assure the correctness and reliability of communication data. When the meter under

communication method, it can make up of collect-disperse systems with epigyny computer; when the epigyny computer、 communication interface or circuitry goes wrong, 808 meter can still hold on its normal working, detailed explanation please refer to meter’s instruction and software CD .

9.3.2 Communication function connection

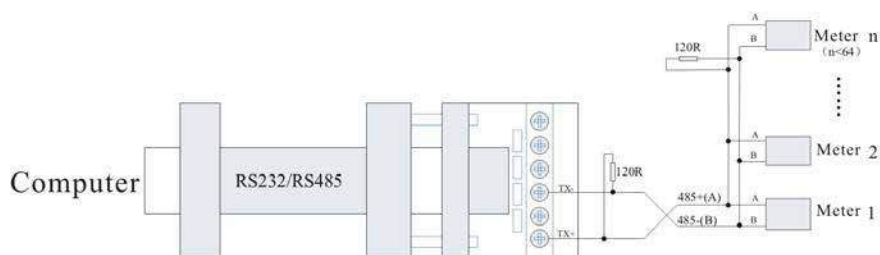

Figure 10-1

Description above is all the function description around the whole series, actual use should be confirm to the purchase meter’s function.

X、 Fault Analysis and Clearance

XMT*808 series adopt advanced production process, and have the strict test before leaving factory, it improve the reliability of the meter .The usual fault caused by the wrong operation or parameter setting .If you find the fault couldn’t be cope with, please record it,and contact with the agent or us.

Sheet 11-1 is the usual fault of XMT*808 series in the daily application:

Sheet 11-1 Common fault handling

fault symptom	analysis of causes	Disposal measurement
Abnormal power (blank screen)	1、 poor contact of power cord 2、 power switch without lose	Check the power
Signal display do not correlate with the facts. (display “orAL”)	1、 Wrong setting of input specification (Sn) 2、 Wrong signal connection. 3、 Sensor break down 4、 Input measurement signal exceed range	1、 check input specification 2、 check signal wire 3、 check the sensor 4、 check input signal
Abnormal alarm output	1、 incorrect alarm defination parameter setting	1、 set alarm definition parameter value again.
Abnormal PID output	Incorrect PID parameter setting, such as proportion、 integral、 differential parameter and so on.	Turn on setting itself again

Attached1: Statement of meter’s parameter attention letter and English letter

A	B	C	D	E	F	G	H	I	J	K	L	M
A	b	C	d	E	F	G	H	I	J	K	L	n

N	O	P	Q	R	S	T	U	Y	
n	o	p	q	r	s	t	u	y	